

3M™ Intelligent Return and Sorter System FX

The future of efficiency

With the intuitive 3M™ Intelligent Return and Sorter System FX, dealing with the check-in and sorting of materials becomes more efficient and virtually effortless. Materials can be returned to the shelf quicker, maximizing the use and convenience of available resources. The process of identifying holds and reserves can be less time consuming. Also, fewer items are missed during check-in, helping to ensure a more precise system and accurate records. Checked in items are immediately removed from the customer's records, reducing the wait for checking out more items. And, your staff can spend more time developing and providing additional programs for your customers.

Reliable Check-in

- Items are instantly checked in and removed from the customer's record
- Improves accuracy
- Customers can immediately check-out items with limits

Modular System

- Up to 4 induction points, including staff induction
- Up to 15 unique sort locations
- Expandable
- Sweep technology

Flexible Options

- Indoor/outdoor returns and staff returns
- Barcode and/or RFID identification
- Electro-magnetic and/or RFID security
- Customer receipt printer and staff printer
- Configurable sort matrix
- Customizable screens

3M Tag Data Manager

- Freedom to move to ISO Tag Data Standard in the future
- Empowers the 3M™ RFID System to read country specific data formats (Danish, Dutch, Finnish and French)

Dimensions

- Intelligent Return Classic
42"L x 20"W x 36"H
(1066.8 mm x 508 mm x 914.4 mm)
Facia: 31.25" x 31.75"
- Intelligent Return Plus
42"L x 20"W x 36"H
(1066.8 mm x 508 mm x 914.4 mm)
Facia: 21.25" x 31.75"
- Intelligent Return Staff
61.5"L x 22.5"W x 36"H
(156 cm x 57 cm x 91 cm)

Energy Profile

100–120 or 200–240 VAC
60 or 50 Hz

Shipping Weight (Approximate)

- Intelligent Return Classic
275 lbs (124.7 kg)
- Intelligent Return Plus
308 lbs (139.7 kg)
- Intelligent Return Staff
320 lbs (145 kg)

- 3M™ Intelligent Return Classic

Push button user interface

- 3M™ Intelligent Return Plus

Graphical user interface

- 3M™ Intelligent Return Staff

Graphical User Interface

- 3M™ Sorter System FX

Sweep technology

Module

Up to 15 bins



UL/ETL Certified

*picture shown represents the 3M Intelligent Return and Sorter System FX

Designed, developed and manufactured by 3M.

3M™ Intelligent Return and Sorter System FX

Just a few examples of how the system can be configured:

5 Bin System

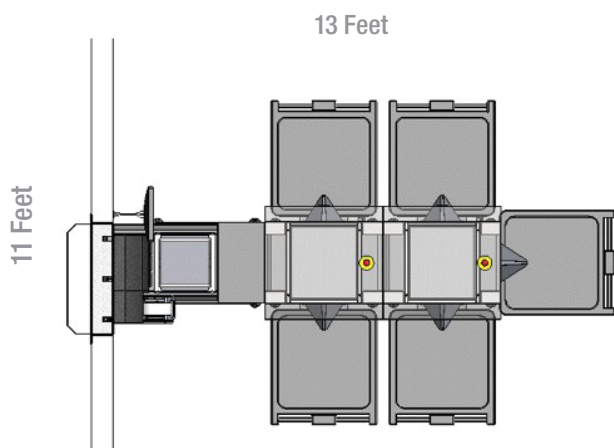

11 Bin System

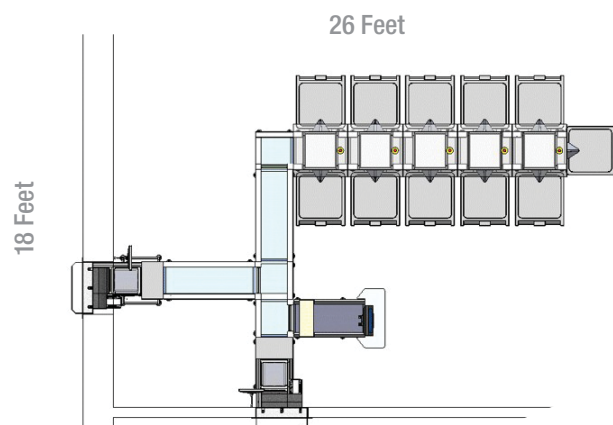

7 Bin System

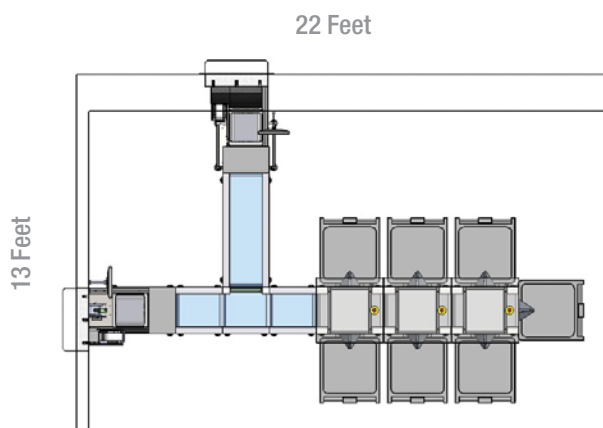

15 Bin System

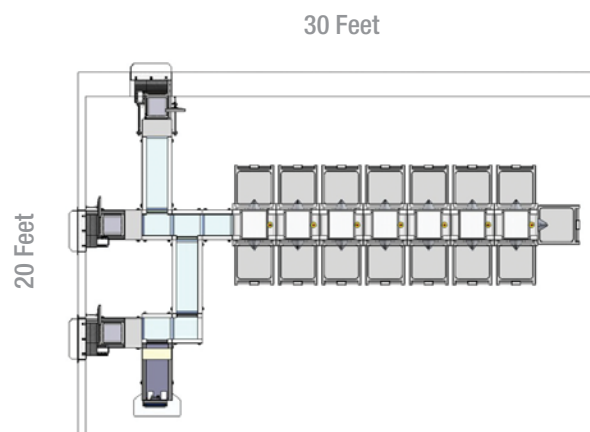

3M Library Systems

3M Center, Bldg. 225-4N-14
St. Paul, MN 55144-1000
USA
1-800-328-0067
www.3M.com/us/library

Please recycle. Printed in USA.
© 3M 2010. All rights reserved.
3M, SelfCheck and Tattle-Tape
are trademarks of 3M.